

Dipole Array Installation Guide

Please Ensure, SAFETY AT ALL TIMES

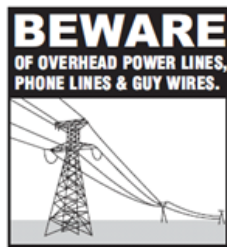

DO NOT INSTALL NEAR POWER LINES, TELEPHONE LINES AND GUY WIRES. THEY ALL LOOK THE SAME SO ASSUME ANY WIRE OR LINE CAN ELECTROCUTE YOU.

Disconnect all power to transmitters related to the installation.

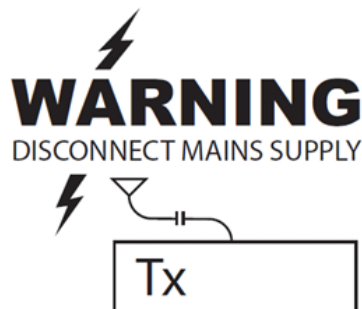

Tools and equipment that may be required:

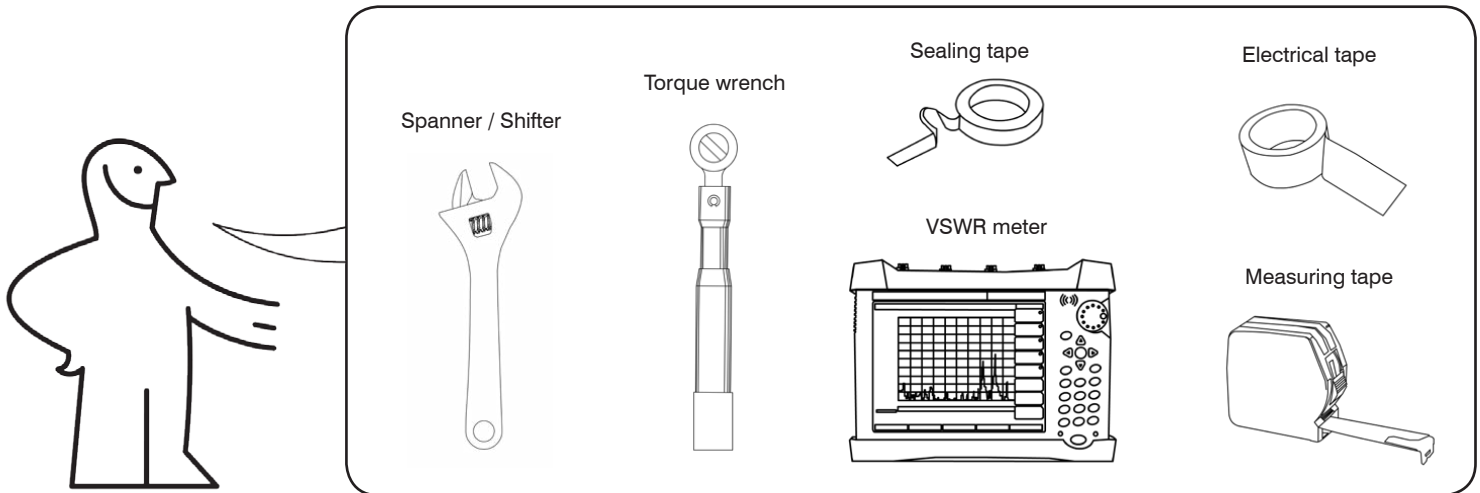

Any **QUESTIONS** contact your RFI representative.

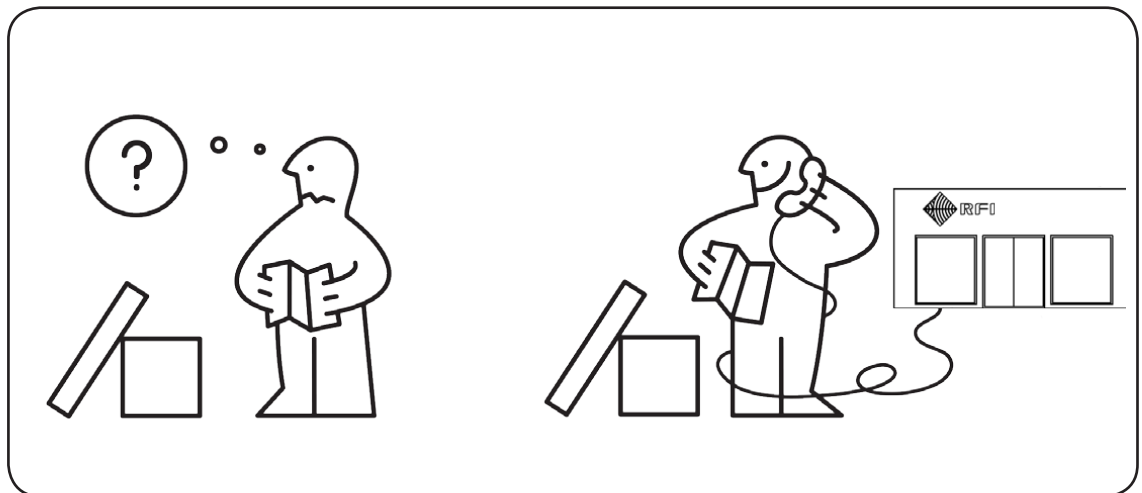



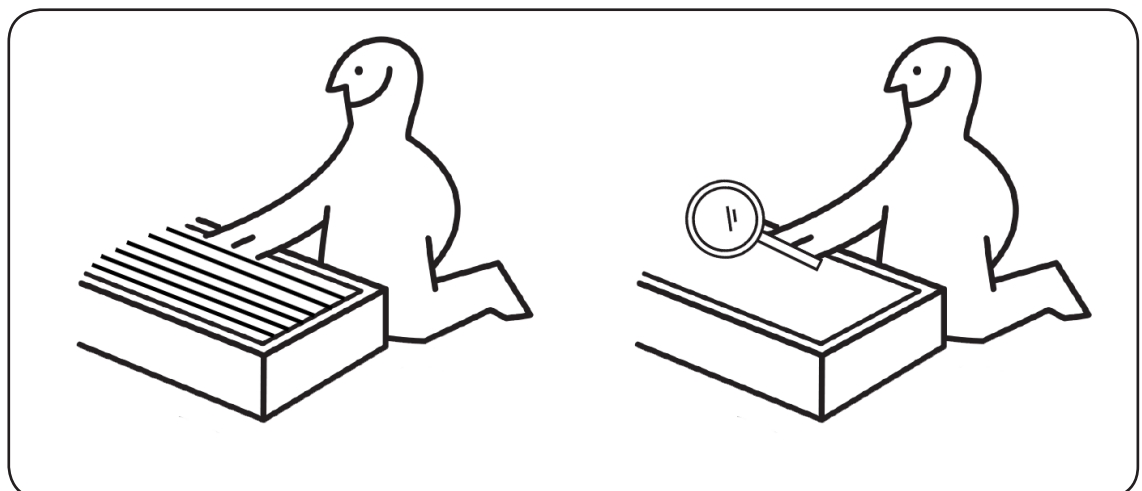



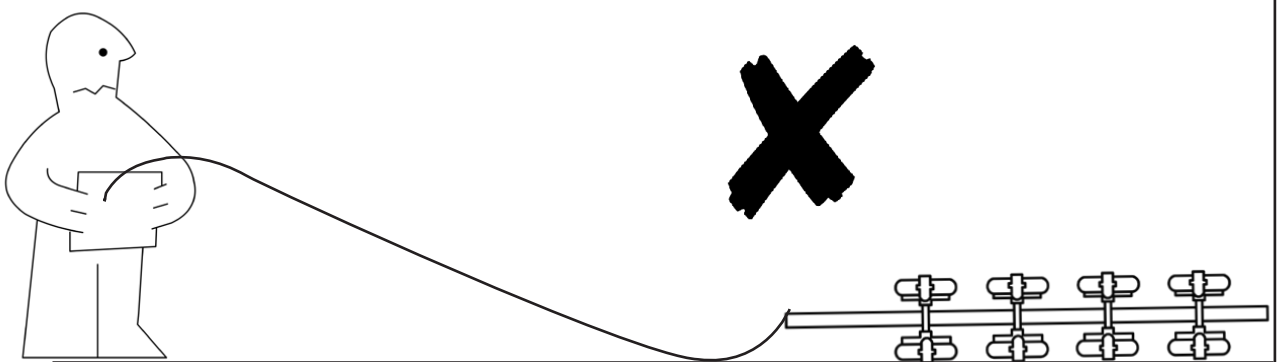
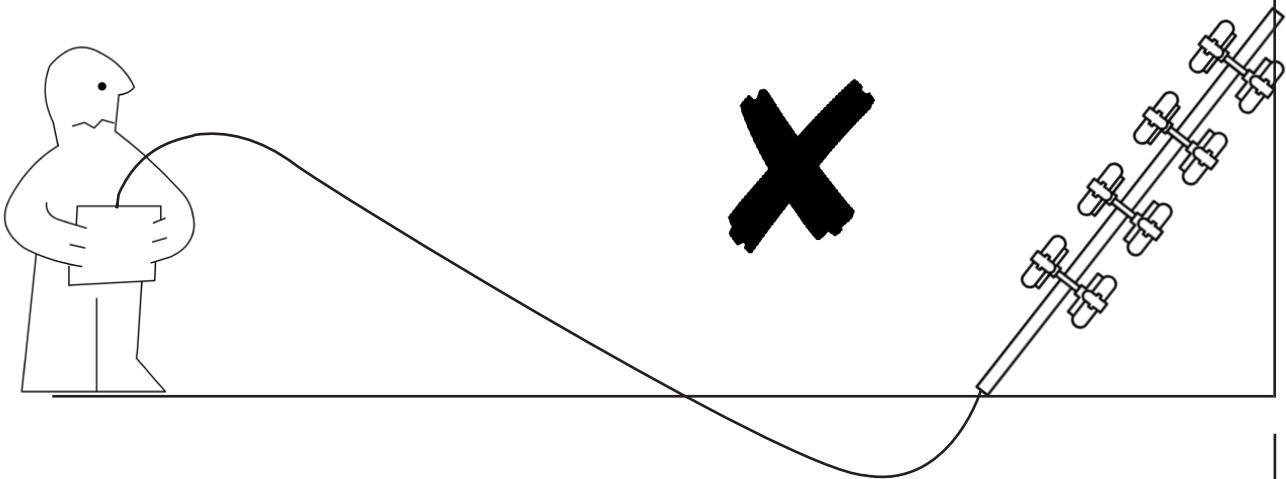
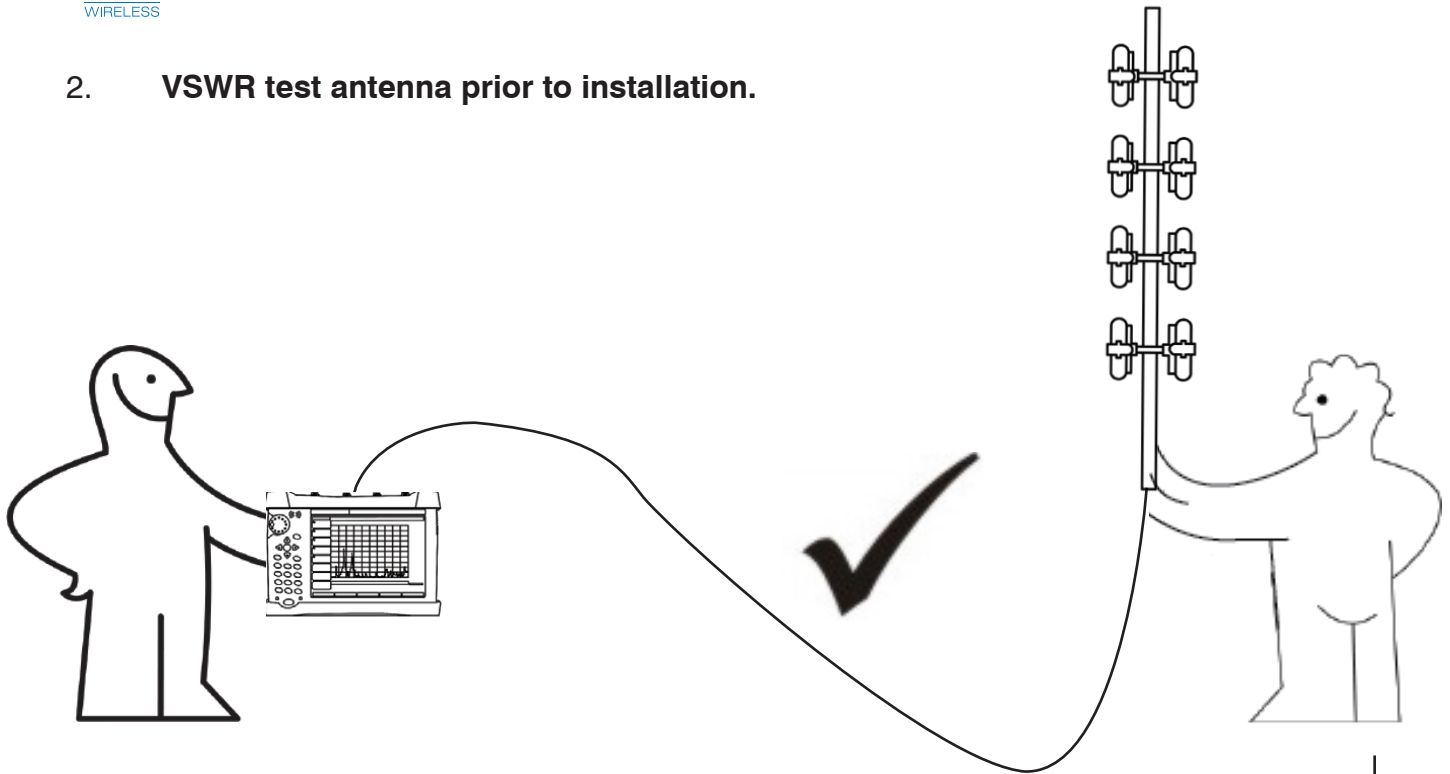

1. Open crate and **inspect** antenna for transport damage before removing from crate.



2. VSWR test antenna prior to installation.



3. Mount antenna vertically, ensure cable tail exits the bottom of the boom.

MOUNTING	GAIN DIRECTION
OA Series (O)	In line with dipoles
	
EA Series (E)	Perpendicular to dipoles
	
BA Series (B)	Omni-directional
	
 Boom	 = Dipole

SIDE MOUNTING

TOP MOUNTING

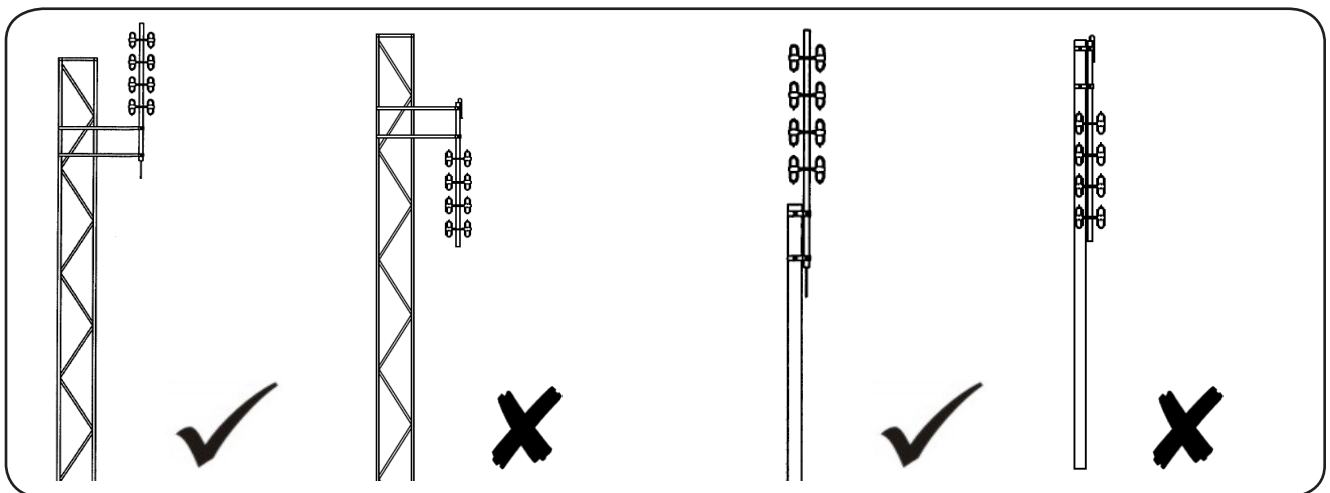

4. **SPACING.** Antenna to **Structure** and **Clamping** dimensions

Band	Frequency MHz	Minimum Antenna to Structure spacing (A)		Clamping dimensions (B)	
		Inches	mm	Inches	mm
VHF	130	91	2308	29.5	750
	145	81.5	2069		
	160	74	1875		
	175	67.5	1714		
	330	36	909		
UHF	345	34	870	19.7	500
	360	33	833		
	375	35.5	800		
	390	30	769		
	400	29.5	750		
	415	28.5	723		
	430	27.5	698		
	445	26.5	674		
	460	25.5	652		
	475	25	632		
	490	24	612		
	505	23.5	594		
	520	23	577		
	IA Series	148-174/400-520	80		

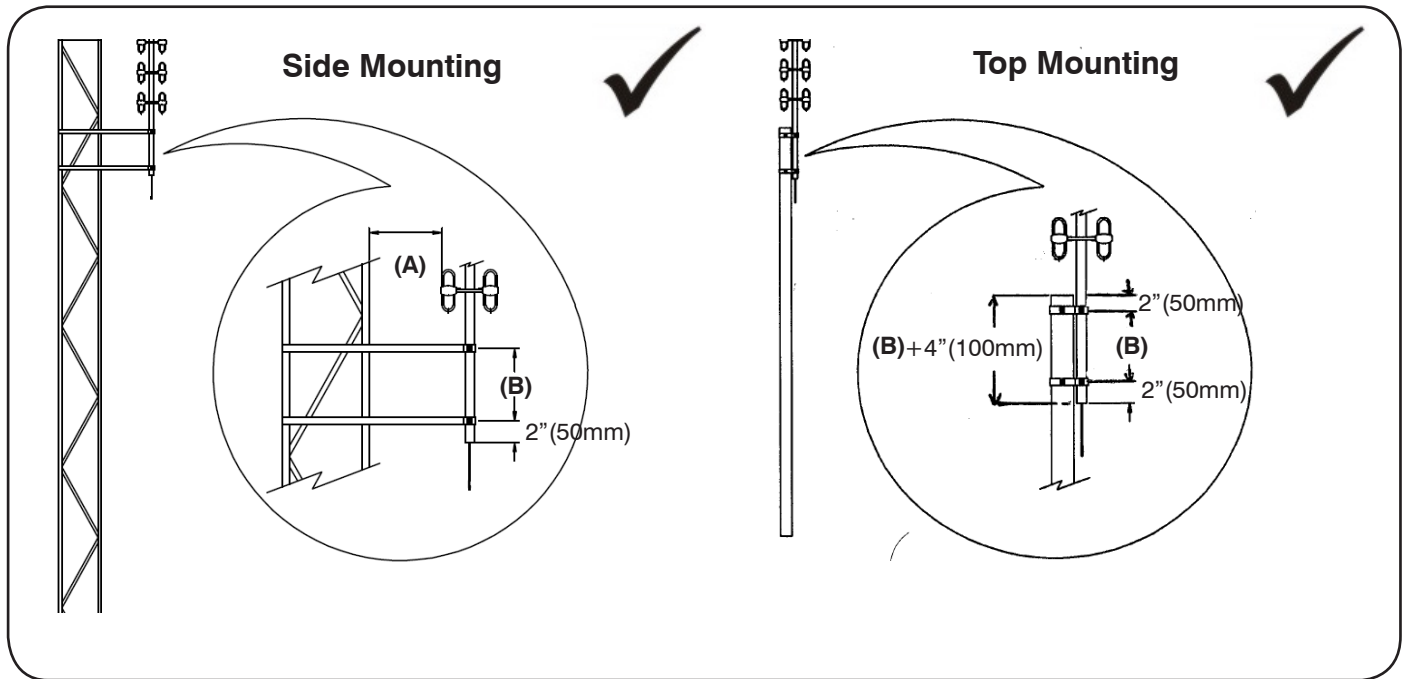

5. **VSWR test** the antenna **after mounting.**

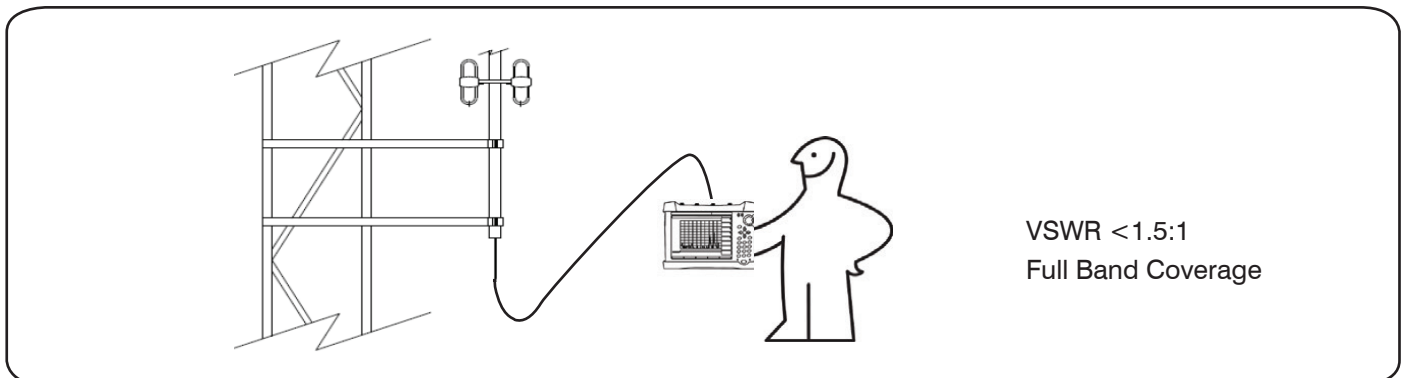

6. Torque connector(s) and weatherproof. Drain loop must be applied.

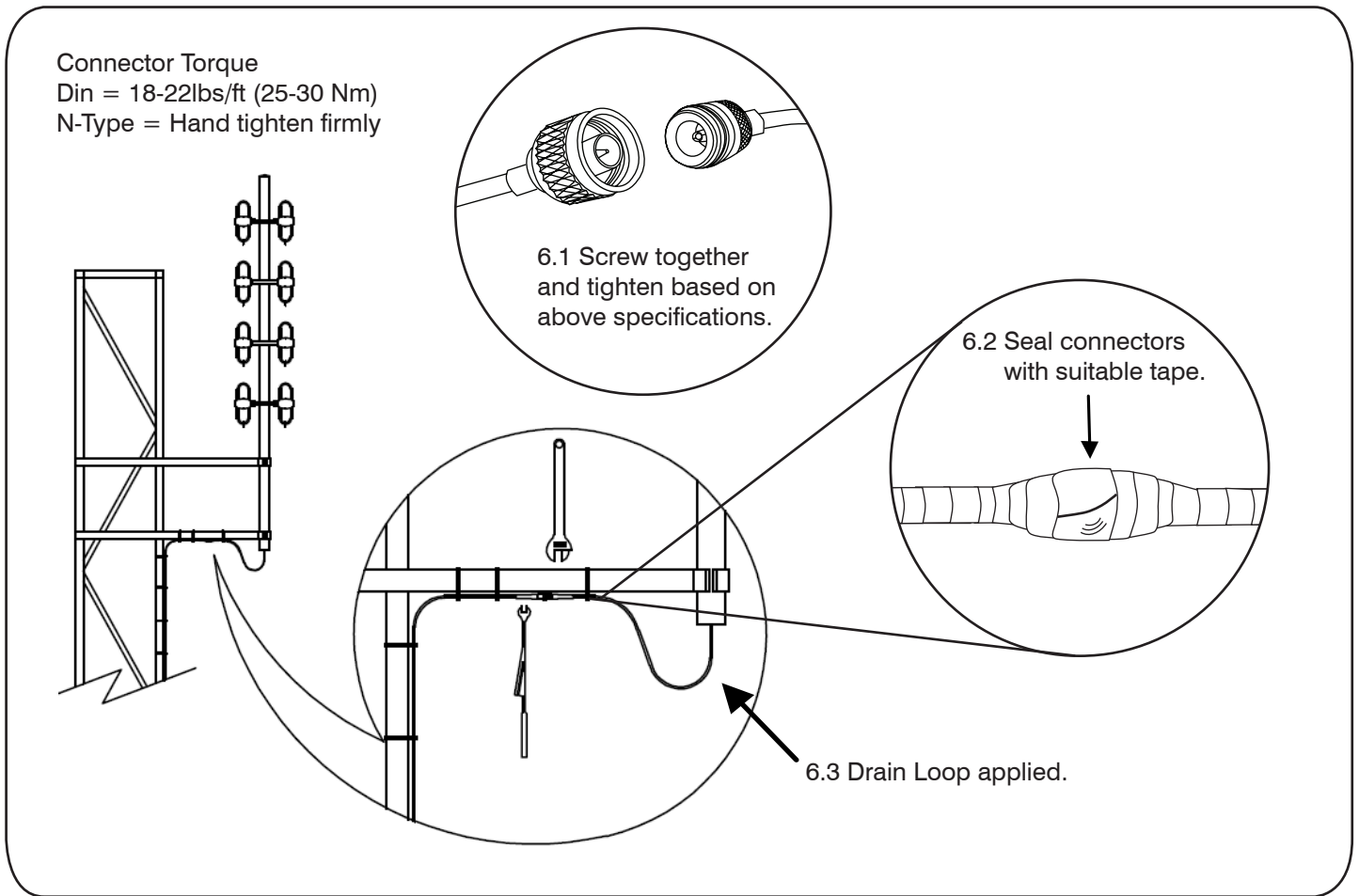

7. Take installation photos and store with VSWR results with site records.

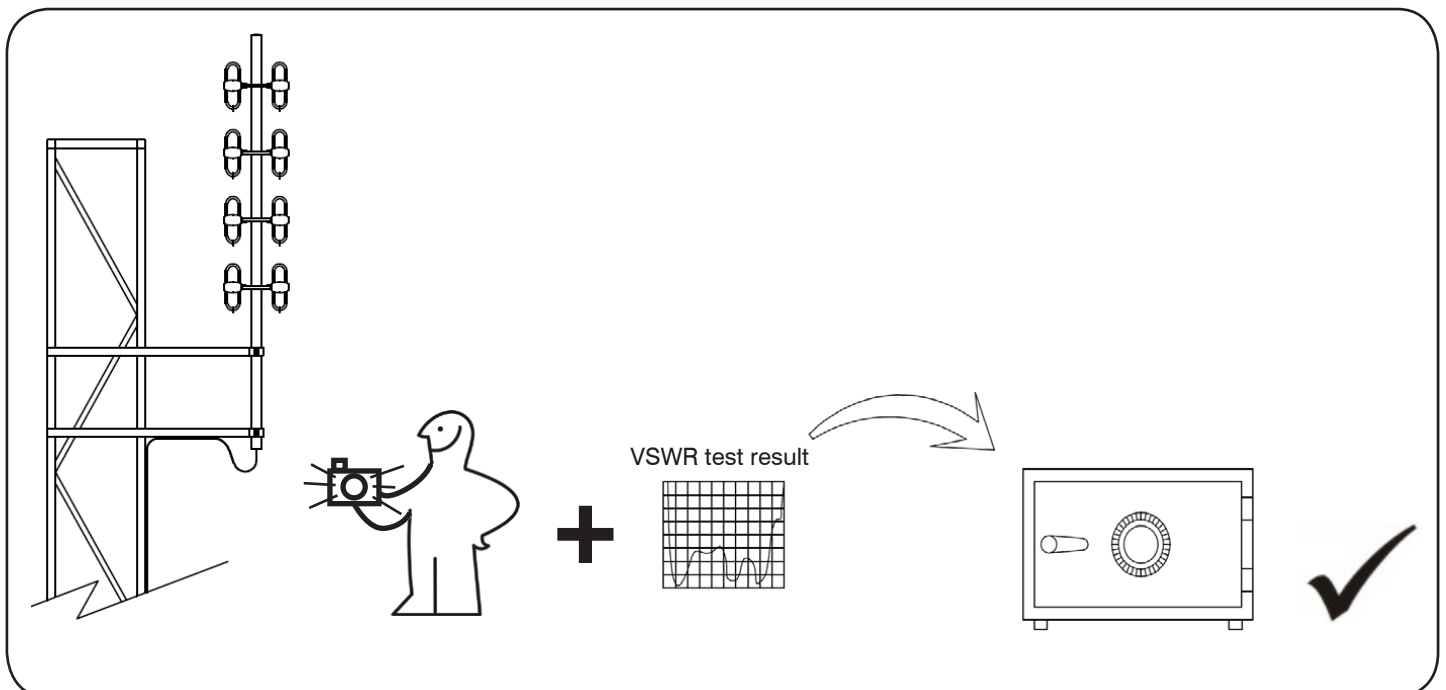

PART 2

Assembly of dual stacked arrays at ground level. (For dual stacked arrays only)

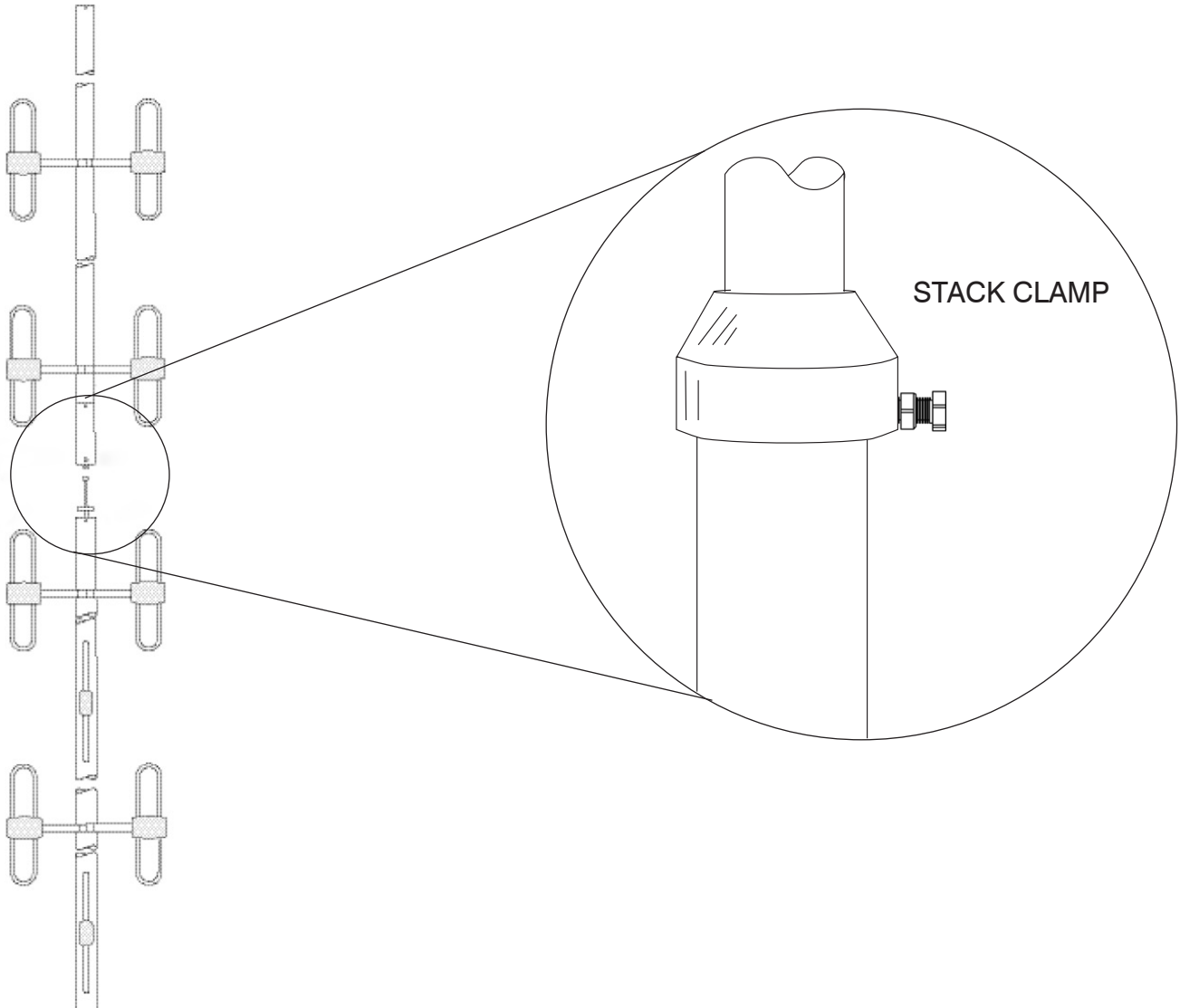

STACK CLAMP PART LIST

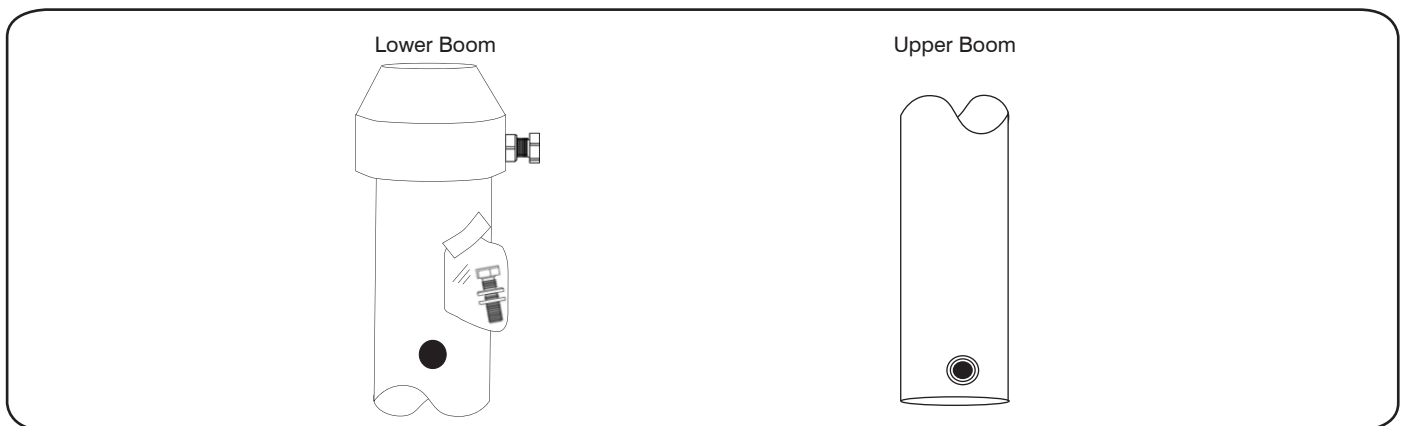

1. Position the cable.

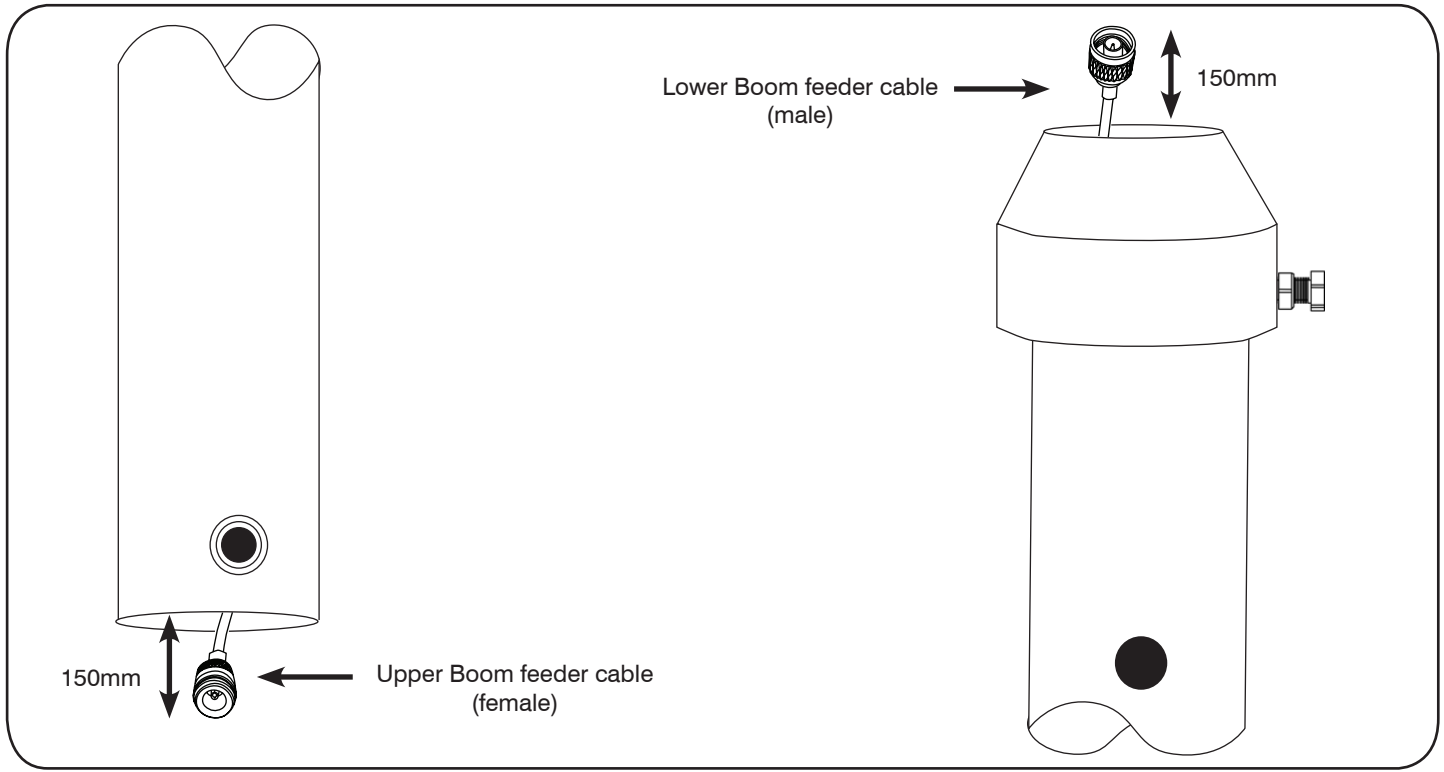

2. Connect cables.

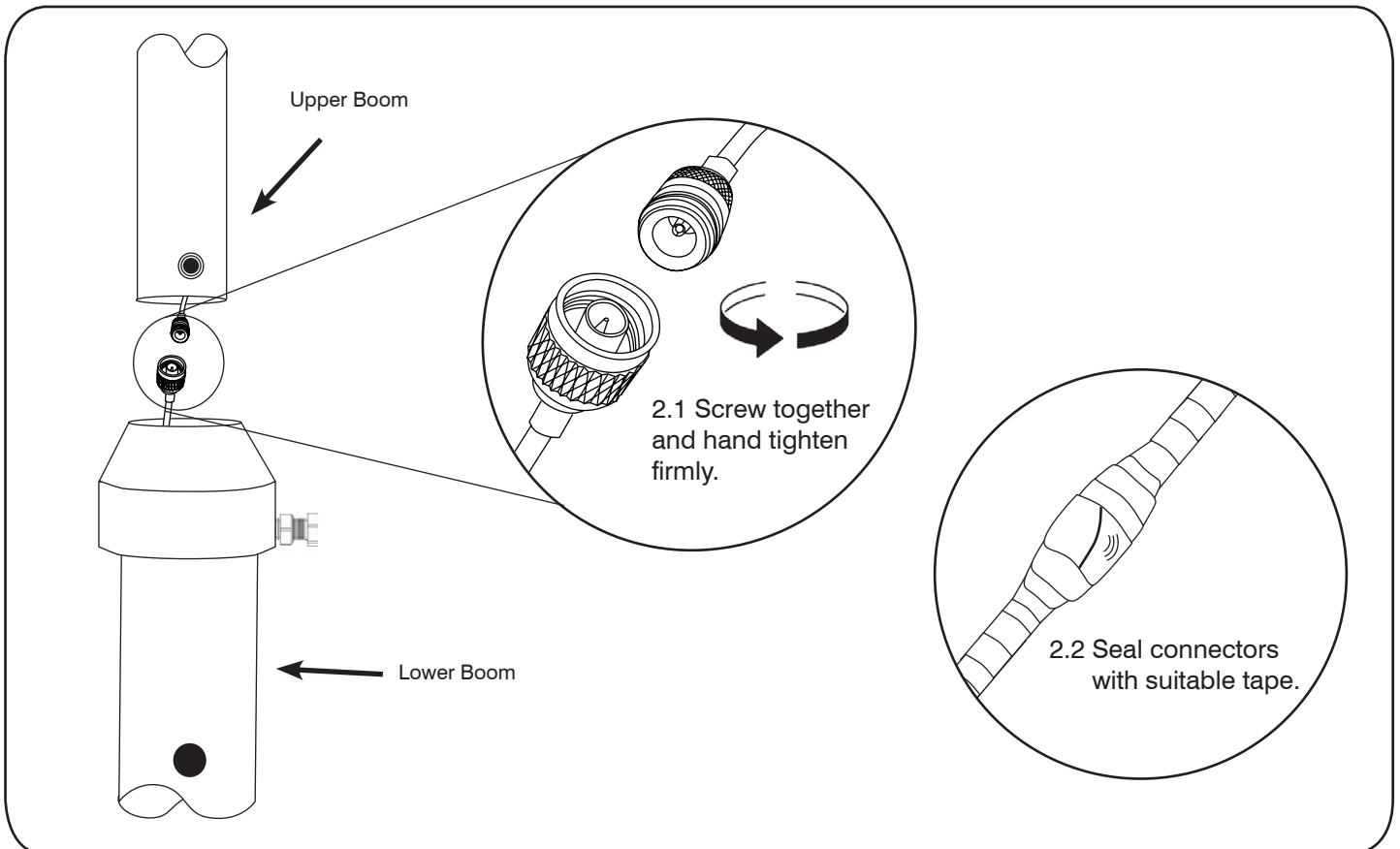

3. Join booms.

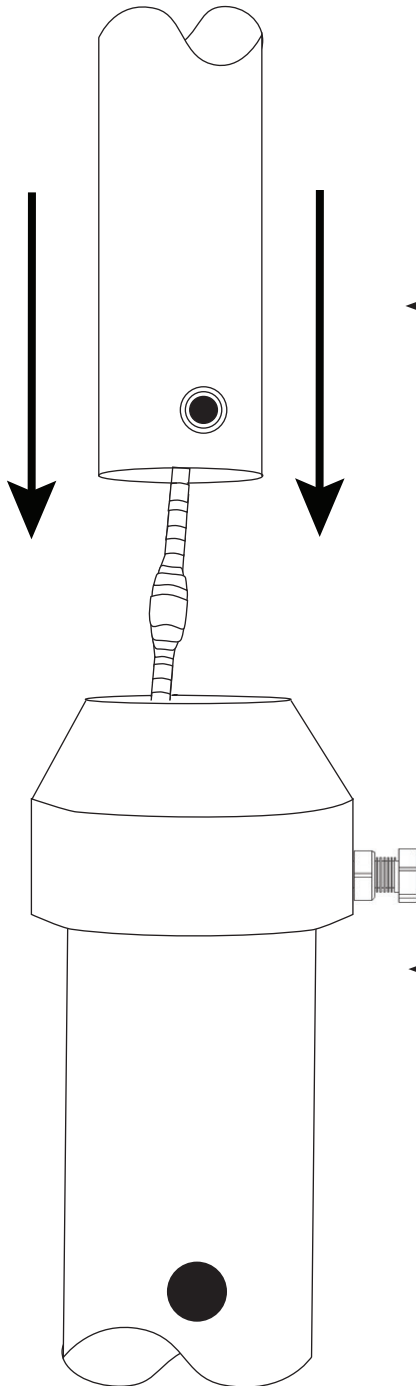

4. Tighten bolt and nut.

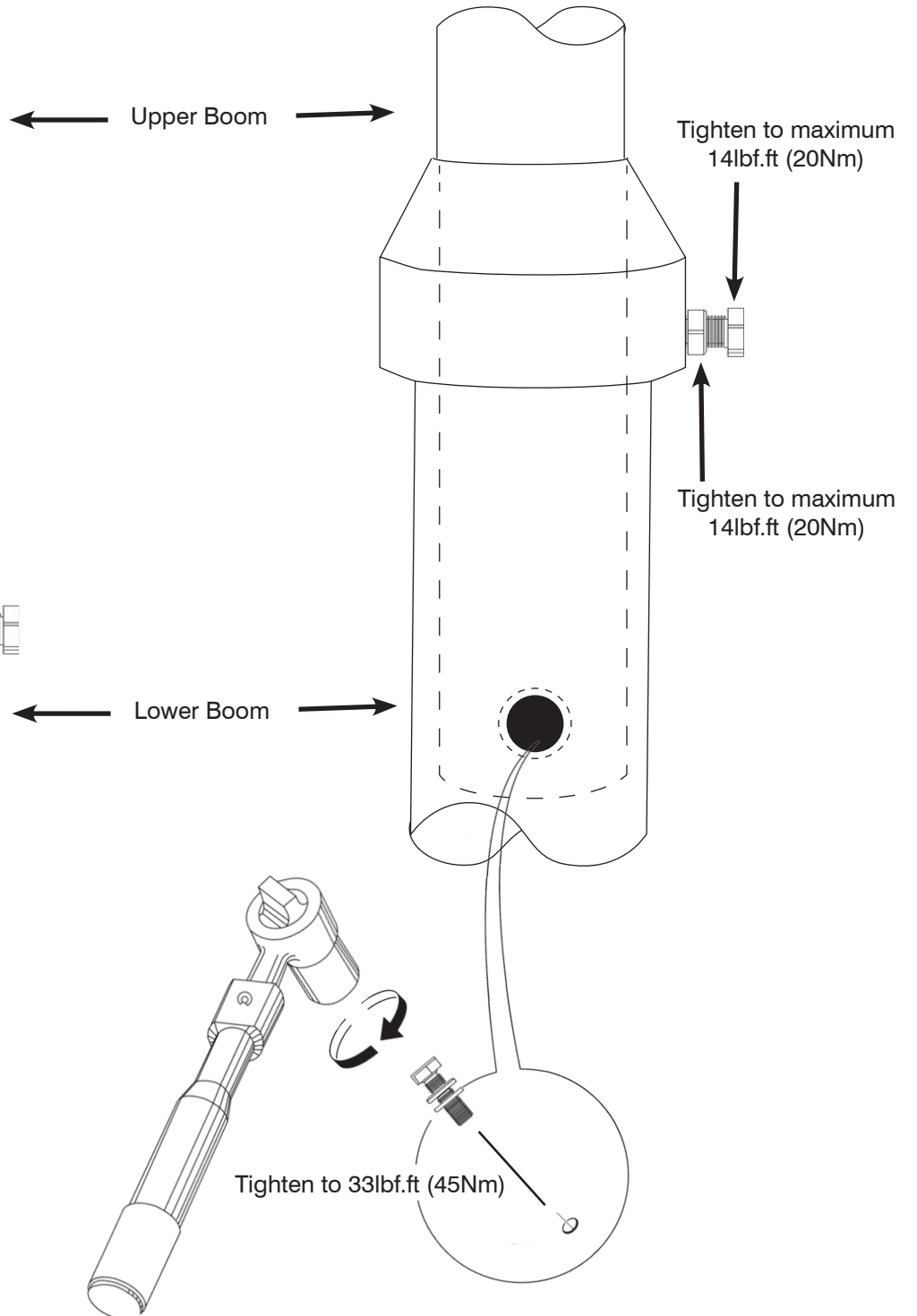

5. VSWR test antenna prior to installation.

